



Assembly Instructions

# LS5013BU

## Under Deck Poly Rail Kit

For use with LS5004BU Leg Bundle.

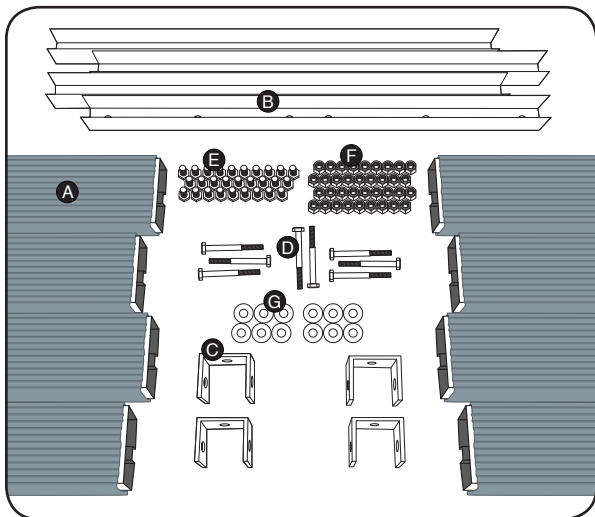

**Under Deck Poly Rail Kit Package**

**PARTS LIST**

ref.	part no.	part name	qty.
A		8' Poly Rail with cap	8
B	21032	Bunk Poly Rail Connector	4
C	21026	Bunk U Channel	4
D	Y412	3/8" x 3" Hex Bolt	8
E	Y403	3/8" x 3/4" Hex Bolt	28
F	Y451	3/8" Nylon Lock Nut	36
G	Y452	3/8" Flat Washers	12

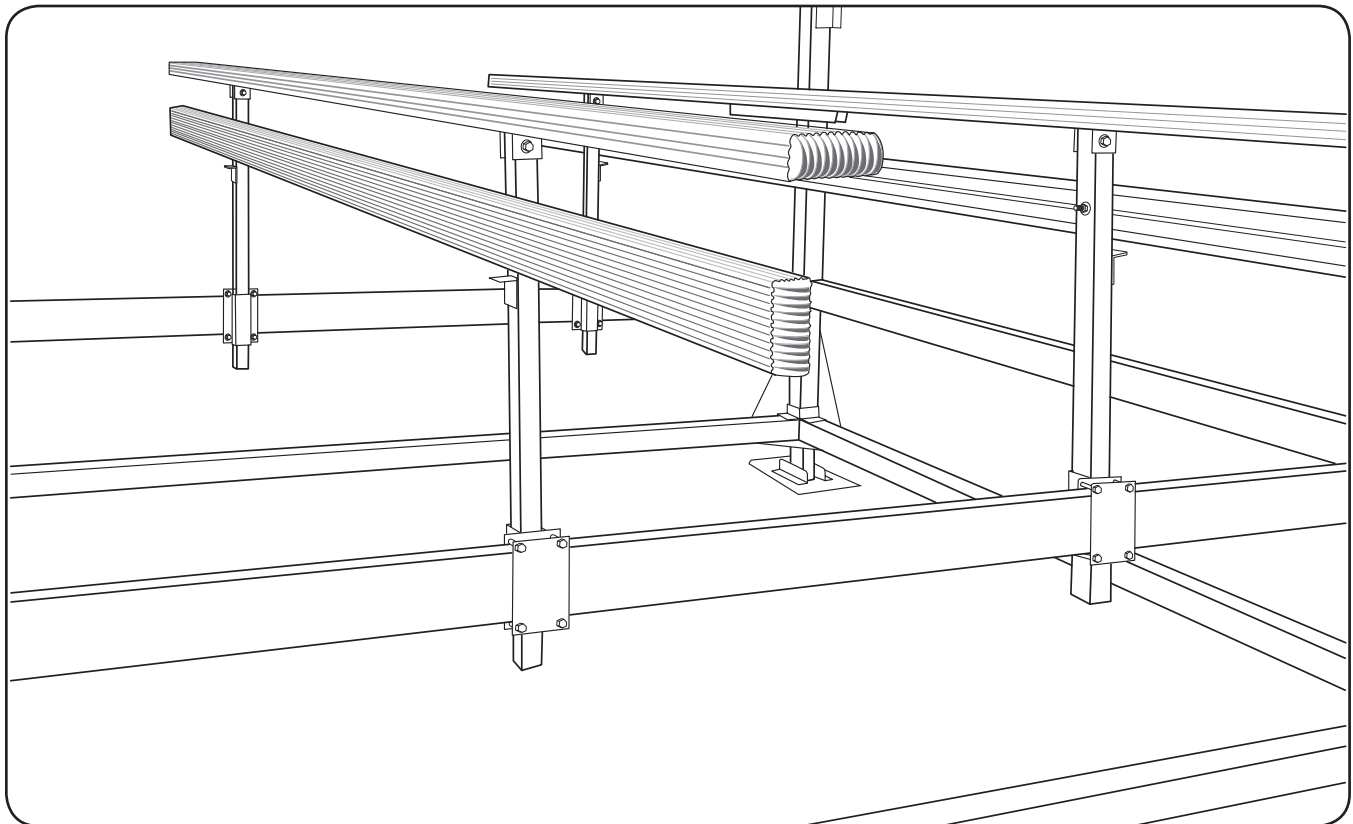

Manufacturers of Lakeshore Products

855 East Chicago Road, Quincy, MI 49082

www.lakeshoreproducts.com • tel: 517.639.3815 • fax: 517.639.4576

# LS5013BU Under Deck Poly Rail Kit (For use with LS5004BU Leg Bundle.)

## tools needed

9/16" Ratchet	1
9/16" Wrench	1

Assembly includes 2 top rails and 2 side rails.

1. Assemble the 2 side rails first. Take (4) 8' **POLY RAILS** and align them so the ends without caps are facing each other. Slide:

- 1 - 3/8" x 3" hex bolt
- 3 - 3/8" x 3/4" hex bolts

(in that order) into the bolt groove on the uncapped end of each **POLY RAIL**. Slide rails together and space the 3/8" x 3/4" hex bolts so that the rail connector can be bolted on, and secure the two **POLY RAILS** together using:

- 6 - 3/8" nylon lock nuts

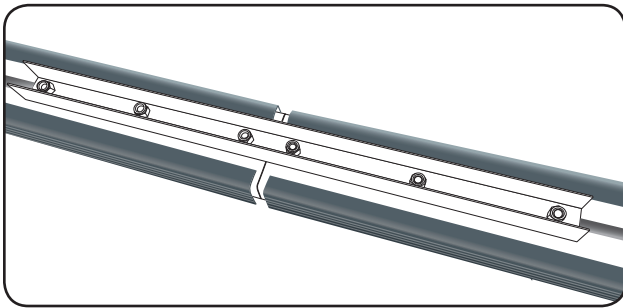
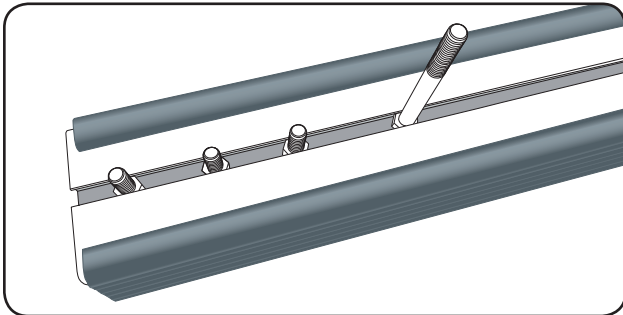

2. Slide the 3/8" x 3" hex bolt so that it lines up with the lower hole in the bunk leg assembly. Push bolt through, add:

- 1 - 3/8" flat washer
- 1 - 3/8" nylon lock nut

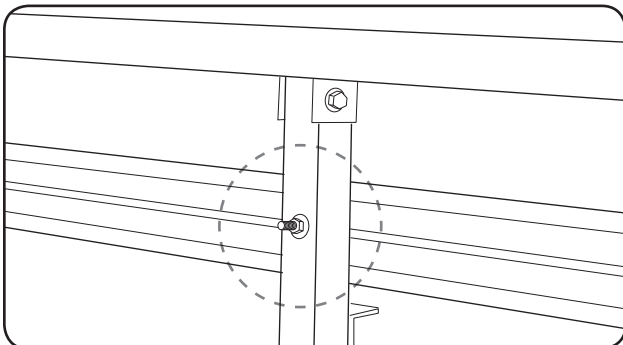

3. Assemble 2 top rails. Take (4) 8' **POLY RAILS** and align them so the ends without caps are facing each other. Slide:

- 4 - 3/8" x 3/4" hex bolts

into the bolt groove on the end of each **POLY RAIL**. Slide rails together and space the 3 hex bolts closest to the uncapped end so the rail connector can be bolted on, and secure the two **POLY RAILS** together using:

- 6 - 3/8" nylon lock nuts

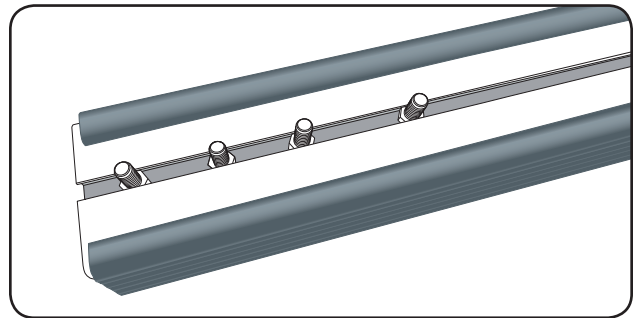

4. Take the 4th hex bolt and secure the **BUNK U CHANNEL** onto the **POLY RAIL**. Slide the **BUNK U CHANNEL** out so that it lines up with bunk leg. Use:

- 1 - 3/8" x 3" hex bolt
- 2 - 3/8" flat washers
- 1 - 3/8" nylon lock nut

to secure rails to upright leg.

NOTE: In some cases the top hole may need to be redrilled for the bolt to fit through.

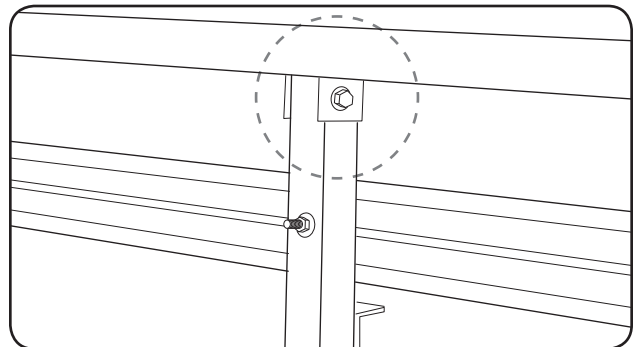

5. Center bunks on lift and tighten all bolts.