

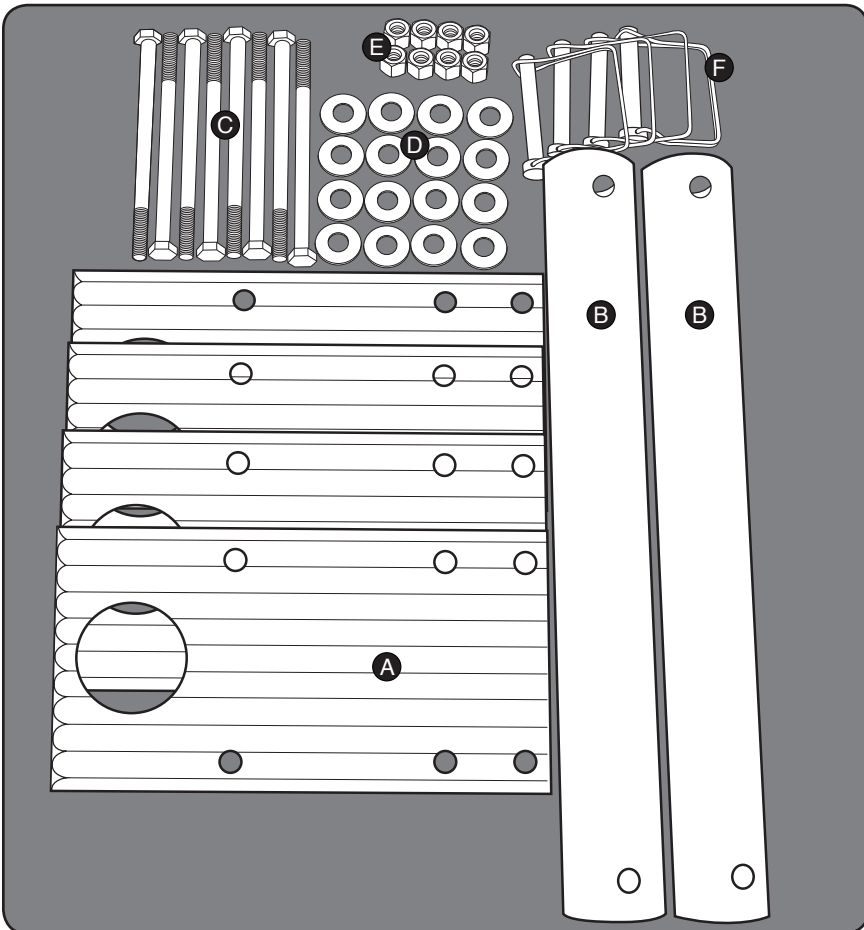

Assembly Instructions

20912B

Wheel Kit Package



20912B Wheel Kit Package

PARTS LIST

<i>ref.</i>	<i>part no.</i>	<i>part name</i>	<i>qty.</i>
A	20913	Wheel Kit Plate	4
B	20914	Wheel Kit Shaft 14.5"	2
C	Y420	3/8" x 5" hex bolt, or:	8
	Y414	3/8" x 3½" hex bolt	8
D	Y452	3/8 flat washer	16
E	Y451	3/8 hex locknut	8
F	CP7	Lynch Pin	4

Manufacturers of Lakeshore Products

855 East Chicago Road, Quincy, MI 49082

www.lakeshoreproducts.com • tel: 517.639.3815 • fax: 517.639.4576

WK Wheel Kit

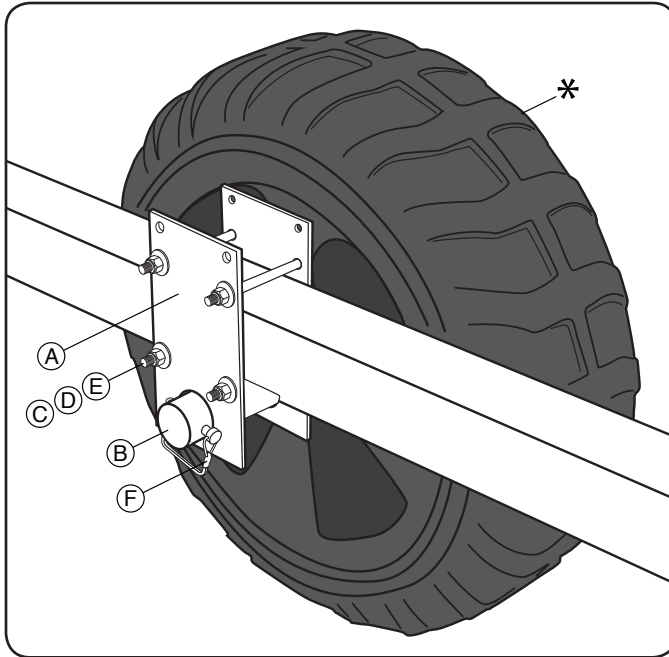

* Wheel shown is 20911 - 25" Black Wheel.
2 are included with WK Wheel Kit.

1. Place two of Plate (A) together.
2. Insert two bolts (C) in the single set of holes in Plate (A) and start the nuts (E) on bolt. Two lengths of bolts are included. Use 5" bolts with B Style Vertical Lifts. Use 3½" bolts with older Vertical Lifts or Cantilever Pontoons.
3. With the large hole in Plate (A) on the bottom, slide the set of Plates upward with one Plate on each side of Frame. Insert two bolts (C) in set of holes closest to top of Frame and tighten.
4. Place Lynch Pin (F) in one end of Shaft (B). Slide Shaft through both Plates from inside Frame to outside Frame. Slide Wheel on Shaft and install Lynch Pin on other end of Shaft.
NOTE: Place Wheel's raised molded hub against aluminum plate.
5. Repeat steps to other side of lift.

NOTE: 2 wheels or 4 wheels may be used.