



Owner's Manual

LSP16H
 LS3001 mainframe bundle
 LS3002H H-unit bundle
 LS3003 accessory box

LSP21H
 LS3101 mainframe bundle
 LS3102H H-unit bundle
 LS3103 accessory box

LSP24H
 LS3201 mainframe bundle
 LS3102H H-unit bundle
 LS3103 accessory box

LSP28H
 LS3301 mainframe bundle
 LS3302H H-unit bundle
 LS3303 accessory box

READ CAREFULLY - FAILURE TO FOLLOW INSTRUCTIONS AND SAFETY RULES MAY RESULT IN SERIOUS INJURY

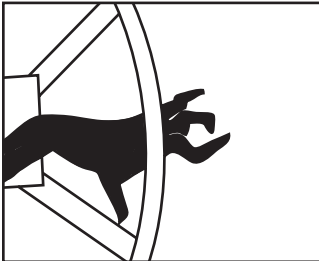

⚠ WARNING
 DO NOT ATTEMPT TO STOP SPINNING WHEEL.
 Serious personal injury could result.
 Lift Wheel must be turned clockwise for lifting.
 NEVER raise lift by turning wheel counterclockwise.
 Doing so will result in an uncontrolled spin down,
 which could lead to cable failure and serious injury.
 Z117

⚠ CAUTION
 DO NOT CRANK PAST STOP POSITION.
 When raising lift be aware that when moving components
 contact frame you have reached maximum height.
 Turning wheel past this point may cause personal injury
 and will cause damage to lift that is not covered by warranty.
 Z119

⚠ WARNING

DO NOT OPERATE THIS HOIST WITHOUT FIRST STUDYING THE OWNER'S MANUAL.

1. Before operating this lift be sure to understand all operating procedures and safety precautions.
 2. NEVER operate lift with people on board boat or near any part of lift.
 3. NEVER work or play on, around or under lift.
 4. NEVER exceed the rated capacity of lift. Doing so may cause lift to fail.
 5. Before use visually inspect SHEAVES and CABLE for wear or fraying. Follow proper maintenance procedures.
- Failure to follow these procedures could cause lift to fail and result in death or serious personal injury.**
 Z116

STEP 1

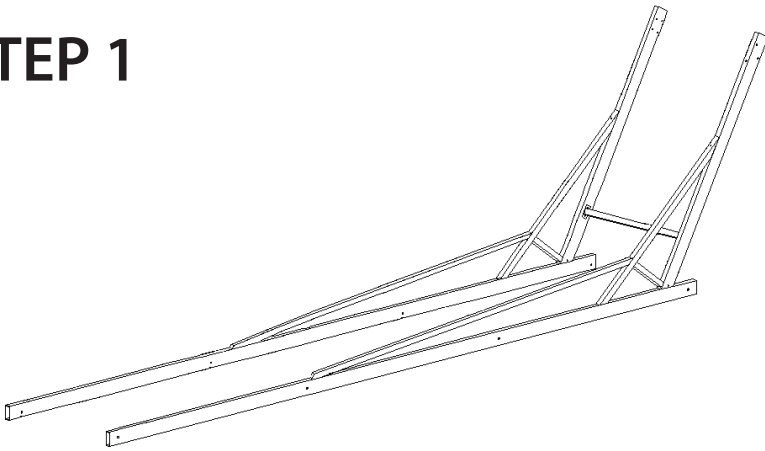

mainframes [9]	2
mainframe spreader lower [11]	1
bolt package #1	1

With proper care and maintenance, this lift will provide you with years of trouble free service. Please follow these instructions carefully.

WARNING

Install all nuts and bolts loosely until the lift is fully assembled, then tighten all nuts and bolts properly.

Do not overtighten the nuts and bolts on your lift.

Doing so may cause the lift to fail. When tightening against a tube, tighten until the aluminum just dimples. If you crush the tube, it may crack and fail under normal use.

tools needed

adjustable wrenches	2
or	
9/16 wrenches	2
3/4 wrenches	2

1.1 mainframe setup

Stand the two mainframes upright. Place the smaller spreader tube between the frames at the bottom of the mainframe upright tube, and attach using:

- 4 – 3/8 x 3 hex bolts
- 4 – 3/8 washers
- 4 – 3/8 nylon lock nuts

Place the washers under the heads of the bolts on the outside of the lift.

STEP 2

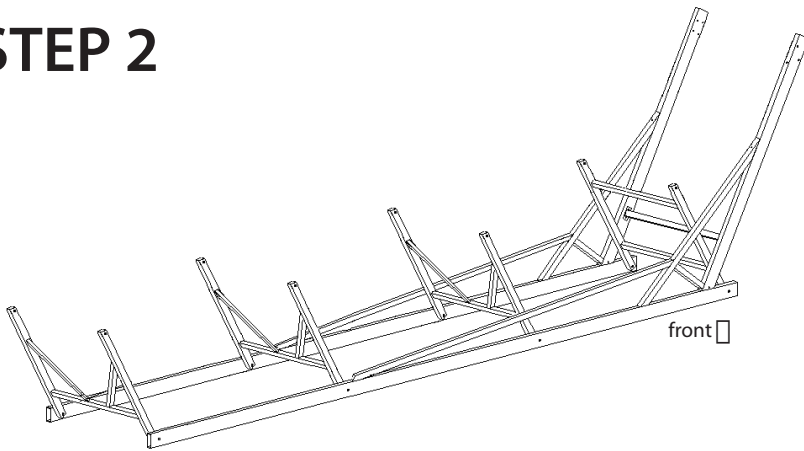

front H unit [10]	1
rear V unit [7]	2/3/4
bolt package #2	1

2. install H-units

Place the H unit between the manframes at the front of the lift with the pulley holes 7" down from the top. Attach using:

- 1 - 1/2 x 5 1/2 hex bolts
- 3 - 1/2 flat washers
- 1 - 1/2 nylon lock nuts

place one washer under the bolt head, one under the nut, and one between the tubes.

Attach the V units in the same manner.

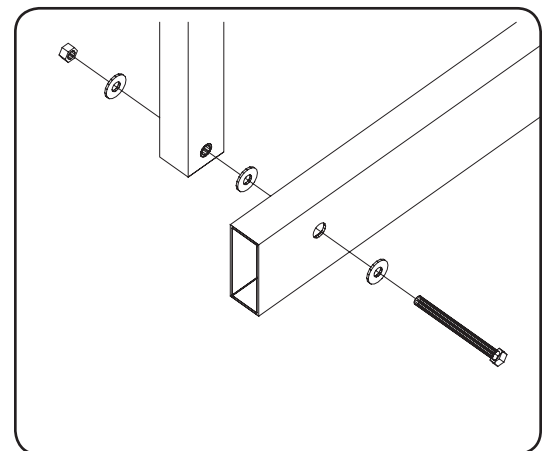

STEP 3

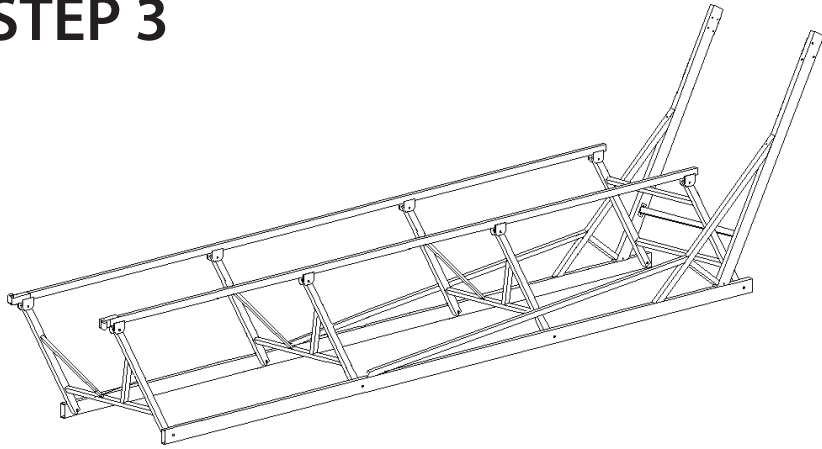

cradles [4]	2
bolt package #3	1

3.1 Install cradles

Lay the cradle tubes in position on top of the H-unit and V-units with the cradle rollers located at the rear of the lift. Turn the drilled tabs to the bottom of the cradle tubes and place over the tops of the leg units, attach using:

- 1 - 1/2 x 3 1/2 carriage bolts
- 1 - 1/2 flat washers
- 1 - 1/2 nylon lock nuts

Be sure to place the nuts on the inside of the lift with the washers underneath them. Repeat for each set of tabs.

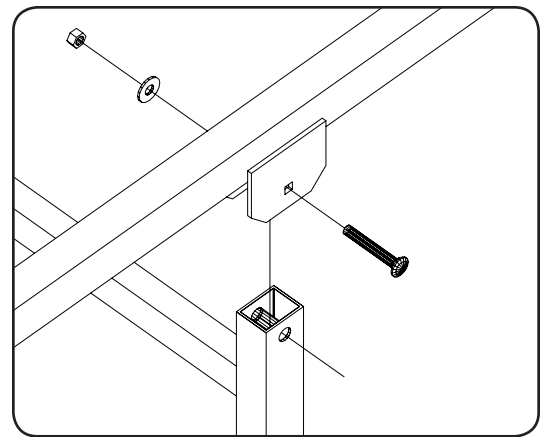

STEP 4

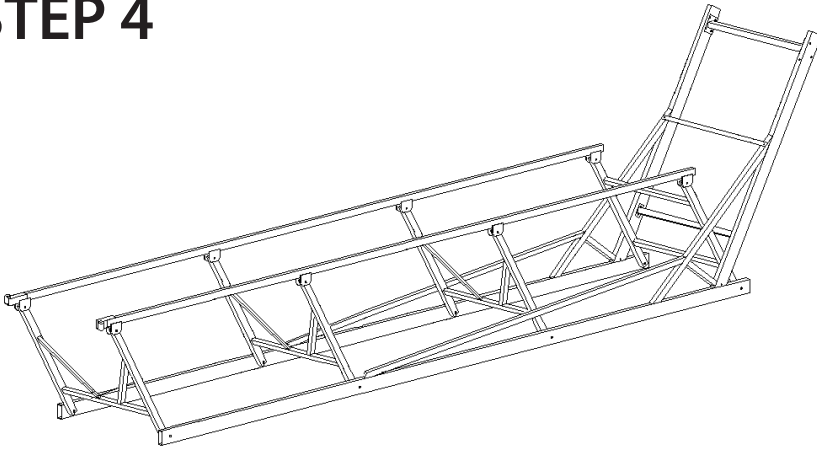

upper spreader tube [12]	1
stop bar [5]	1
bolt package #4	1
cable [15]	1
wheel support tube [20]	1
bolt package #4	1

4.1 Install upper spreader and stop bar

Attach the upper spreader tube to the side opposite the winch using bolt package #4:

- 1 - 1/2 x 3 hex bolts
- 1 - 1/2 flat washer
- 1 - 1/2 nylon lock nuts

bolt through the mainframe and into the bottom hole of the plate.

Lay the cable out straight and bolt through the upper hole of the spreader tube using:

- 1 - 1/2 x 3 1/2 hex bolts
- 1 - 1/2 flat washer

Install the looped end of the cable over the bolt using:

- 1 - 3/4 flat washer
- 1 - 1/2 flat washer
- 1 - 1/2 nylon lock nuts

be sure to tighten so that the cable will not come loose.

Install the stop bar on the mainframe brace using:

- 2 - 5/16 x 3 1/2 hex bolts
- 2 - 5/16 nylon lock nuts

be sure that the STOP label is visible.

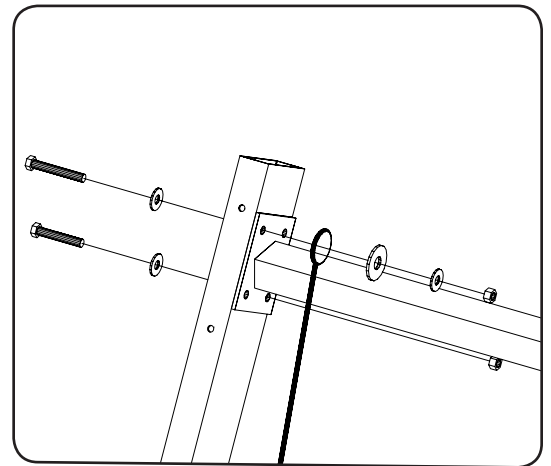

4.2 Wheel support tube

Attach the wheel support tube and the other end of the upper spreader tube to the mainframe with bolt package #5:

- 2 - 1/2 x 3 1/2 hex bolts
- 2 - 1/2 nylon lock nuts

the bolt heads should be on the outside of the lift.

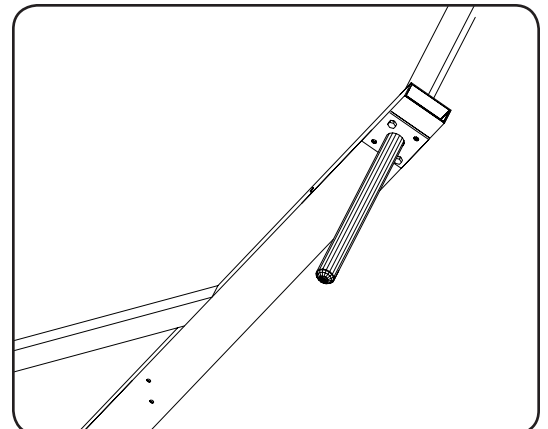

STEP 5

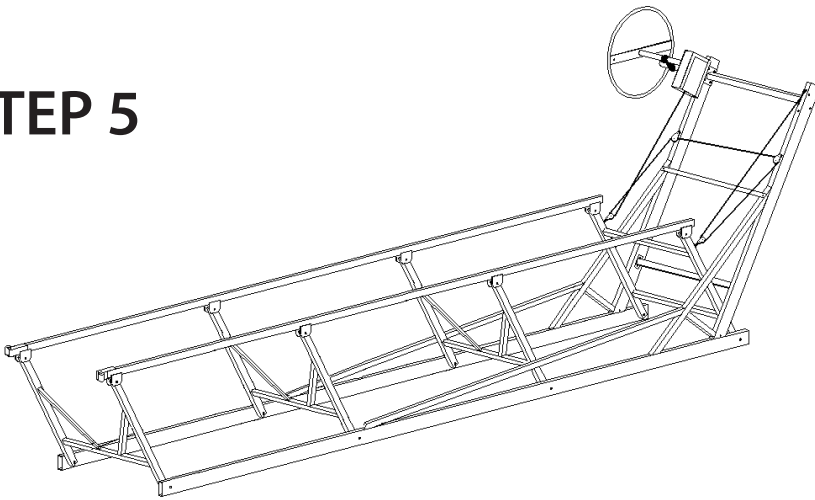

winch #5 [13]	1
wheel extension tube [27]	1
wheel support bracket [21]	1
32" wheel [26]	1
3" pulley kit [31]	2
6" pulley kit [3]	2
red cap 2" x 2.5" [33]	2
red cap 2" x 5" [1]	2
bolt package #5	1/1

5.1 Mounting the winch.

In attaching the winch to the mainframe tube, place the winch shaft towards the outside of the lift.

- 2 - 3/8 x 6 1/2 hex bolts
- 2 - 3/8 flat washers
- 2 - 3/8 nylon lock nut

with the washers and nuts inside the winch. These are in bolt package #6.

5.2 Wheel

Bolt the wheel extension tube to the winch shaft. Slide the white portion of the wheel support bracket over the wheel extension tube. Turn the bracket until you can slide it just past the end of the wheel support tube. Adjust so that the tubes are parallel and tighten the bolt that holds the bracket in position. Bolt the wheel to the wheel extension tube and tighten to secure.

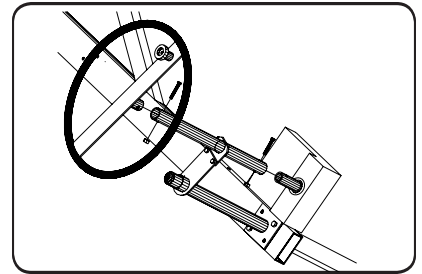

NOTE

Never over crank the winch. Once the lift has reached its highest point, further cranking will damage the lift.

5.3 Install pulleys

Install the 3" pulleys to the front of the h-unit and the 6" pulleys to the mainframe upright tubes in the holes that are approximately 12" below the upper spreader tube. Secure using:

- 4 - 1/2 flat washers

5.4 String cable

Take the loose end of the cable and run it over the pulley on the H-unit closest to where the cable is attached. String it back through the mainframe pulley on the same side of the lift and then over through the mainframe pulley on the opposite side. String under the remaining H-unit pulley. Locate the cable hole in the winch drum inside the bottom of the winch. The drum may have to be turned so the slot and the clamp screws are accessible. Loosen the clamp screw and thread the straight end of the cable through the hole until approximately 1" is sticking out. Tighten the clamp screws down with a 5/32 allen wrench until the cable is held securely. This is done through the hole in the side of the winch next to the shaft.

NOTE

The wheel needs to thread on and off the shaft to activate the brake. This shaft should be greased yearly to ensure proper operation.

Extreme care should be taken not to cross thread and damage the threads on the wheel hub. This will void your warranty.

Take up the slack in the cable by turning the wheel clockwise. Make sure the cable winds evenly as in the figure above right. Double check that the lift is working properly as it is raised and that all pulleys are turning freely. After the first few times the winch is used check the clamp screws for tightness and tighten if required.

5.5 Final adjustments

Now tighten all nuts and bolts, except the ones that must be free to allow the H-units to pivot. Install the 4 red plastisol caps, 2 at the top of the mainframe and 2 on the cradle tubes. Move your lift into the water and position it so that the lift is level. If your lake bottom is uneven, we offer Leg Kits that enable you to level your pontoon lift. The installation is now complete.

helpful hints

- A. Deep water ?
- B. Extension legs are available in 1', 2', 3' and 4' lengths. Call your Dealer for pricing. If you use legs keep in mind that the mainframe must be supported every 8 feet.
- C. The Cable will last much longer if you grease the first 5' to 8' that goes into the winch.
- D. The winch and brake mechanism will work better if the wheel shaft is greased yearly. This task has been simplified by the addition of a grease fitting on the wheel shaft right behind the red wheel.
- E. Do not overcrank your lift. Be sure to notice the maximum height that your lift will rise to and STOP when you reach that height. Failure to do so will damage your lift.
- F. Do not overload. Never exceed the rated capacity of your lift. Keep in mind that fuel, water, and gear all count towards the weight of your boat.
- G. NEVER allow anyone to play on, under, or around the lift.
- H. Only raise your lift CLOCKWISE. Turning your wheel counterclockwise will raise your lift but it will not allow the clutch braking mechanism to engage. This means when the wheel is released an uncontrolled spin down will happen. If this happens DO NOT ATTEMPT TO GRAB THE WHEEL. Instead let it spin down on its own, this will not damage the hoist or boat. Attempting to stop the wheel may result in serious injury.

Ten/Two Year Limited Warranty

LSP, Inc. (Seller) warrants the aluminum structure on docks and lifts of its manufacture to be free from defects caused by faulty material or poor workmanship. Seller will, at its option, repair or replace any such goods found on examination by Seller, to be defective under normal use and service within ten years from date of purchase. Upon discovery of any such defect, Buyer must notify Seller in writing of defect and provide proof of purchase. Seller warrants cast aluminum parts, mechanical components, and hardware for two years.

Seller shall not be held responsible for repairs or modifications to its docks or lifts unless authorization has been obtained from Seller. This warranty does not cover damage caused by incorrect assembly or adjustments, overloading, improper use, neglected maintenance, alterations, or damage caused by accident, ice, salt water, or acts of God.

Components obtained from other manufacturers and used in Seller's products will be covered under the manufacturer's warranty and shall not be the responsibility of the Seller.

Seller's responsibility under this warranty shall be the repair or replacement of defective items. Seller is not liable for incidental or consequential damages of any kind.

LSPH accessory package

bolt package with steps 1-5	1
wheel extension tube 24"	1
wheel support bracket	1
aluminum winch	1
cable with loop in one end	1
3" pulley kit	2
6" pulley kit	2
2" x 2.5" red plastisol caps	2
2" x 5" red plastisol caps	2
caution decal	1

LSP16H, 21H, 24H, 28H Cantilever Pontoon Lift

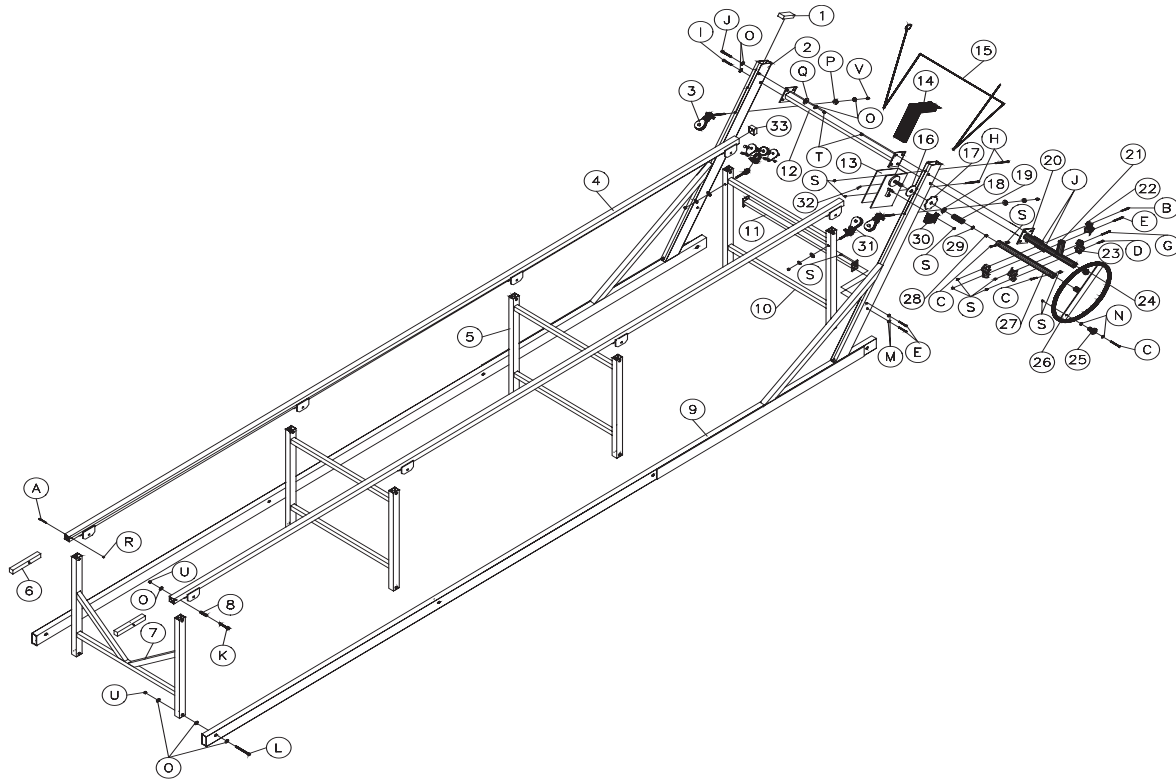

PARTS LIST

ref.	part no.	part name	qty.
1	DEM25	2" x 5" plastisol cap	2
3	PUL6	6" pulley kit	2
4	20390/20391/ 20392/20393*	cradle weld assy	2
5	20876	stop bar	1
6	PRK	pontoon roller kit	2
7	20590	rear V-unit	2/3/3/4*
9	20159/20161/ 20163/20389*	mainframe	2
10	20583	front H-unit	1
11	20581	spreader tube lower	1
12	20579	spreader tube upper	1
13	W5	3500 lb. Winch	1
15	20640	cable 1/4" x 37'	1
19	WSL	winch shaft adapter	1
20	20111	wheel support tube	1
21	20888	wheel support assembly	1
25	20552	spinner knob assembly	1
26	LS3004	32" pontoon wheel	1
27	20021	wheel extension tube	1
28	Y304	5/16" x 1" hex bolt	1
29	X452	3/8 washer	1
31	PUL3	3" pulley kit	2
33	DEM22	2" x 2 1/2" plastisol cap	2

BOLT LIST

ref.	part no.	part name	qty.
A	Y310	5/16 X 2 1/2 Hex Bolt	2
C	Y410	3/8 X 2 1/2 Hex Bolt	3
E	Y412	3/8 X 3 Hex Bolt	6
H	Y426	3/8 X 6 1/2 Hex Bolt	2
I	Y512	1/2 X 3 Hex Bolt	1
J	Y514	1/2 X 3 1/2 Hex Bolt	3
K	Y514C*	1/2 X 3 1/2 Carriage Bolt	6/8/8/10
L	Y522*	1/2 X 5 1/2 Hex Bolt	6/8/8/10
M	Y452	3/8 Flat Washer	8
N	X452	3/8 Stainless Flat Washer	2
O	Y552*	1/2 Flat Washer	31/39/39/47
Q	Y652	3/4 Flat Washer	4
R	Y351	5/16 Lock Nut	2
S	Y450	3/8 Hex Nut	14
T	Y550	1/2 Hex Nut	4
U	•Y551	1/2 Lock Nut	16/20/20/24
V	G550	1/2 Galvanized Hex Nut	4

* LSP16H/LSP21H/LSP24H/LSP28H